

# Technical Bulletin 059 – Zero EV Installation Guide

Rev1 29/11/2021

The Lifeline Zero EV fire suppression system is homologated to FIA 8865-2015 and using 3M™ Novec™1230 fire suppression fluid, is accepted by the FIA for use in hybrid and fully electric vehicles as a non-conductive extinguishant. It has also been extensively tested against a variety of fuels including bio and carbon neutral fuels.

The information below provides a guide to installing your chosen system. Unfortunately, due to the variety of vehicles being raced the exact location of the components of the systems cannot be fully defined by Lifeline; this document provides “best practise” advice suitable for most vehicles. If you feel that your installation cannot follow these guidelines, please contact Lifeline Technical for further guidance.

*Fully read and understand the instructions below before starting installation. Plan your installation carefully referring to the tables below and the system drawings. Do not cut the supplied tubing or the plug and lead sets until you are certain of the location of the cylinder, connectors, nozzles, switches and power pack.*

## Other References (Available at [www.lifeline-fire.co.uk](http://www.lifeline-fire.co.uk))

<b>TB001</b>	System Care, maintenance, and Service
<b>TB003</b>	Novec MSDS
<b>TB061</b>	Zero EV – Kit Content and Spares

## 1 Cylinder Installation

Mount the cylinder transversally or longitudinally in the car, and within the safety cell/roll cage.

Avoid positions where the cylinder is likely to be damaged, abraded or exposed to extreme heat.

The Homologation and maintenance labels must be visible for scrutineering.

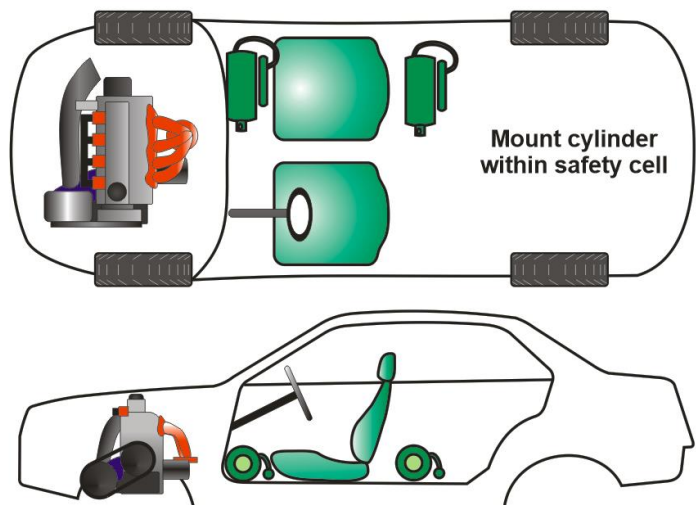

Figure 1 Cylinder position is free within the safety cell/roll cage

Secure the cylinder bracket to the car using M6 nuts and bolts. Use vibration washers or nyloc nuts. Do not use self-tapping screws. The use of anti-vibration mounts appropriate for the vehicle is highly recommended.

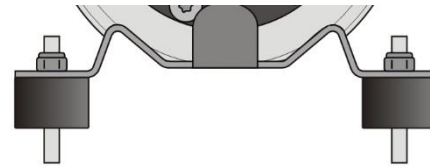
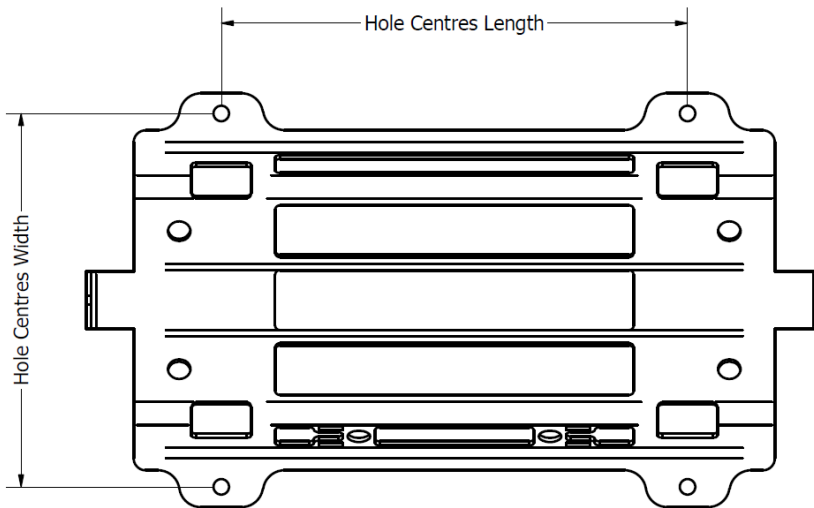

Figure 2 Example of Anti-Vibration Mounts



Hole Centres	
Length	195mm
Width	153 ± 2mm

It is permitted to use bracket and straps of your own design provided it conforms to Appendix J, Art. 253 of the FIA International Sporting Code.

Thread the T-Bolt steel straps through the slots on the bracket. Place the cylinder inside the straps and tighten the straps using an 11mm socket. Ensure the cylinder is secure but do not overtighten.

Place the Remote Charge on the side mount on the bracket. Secure to the mount using the two cable ties provided

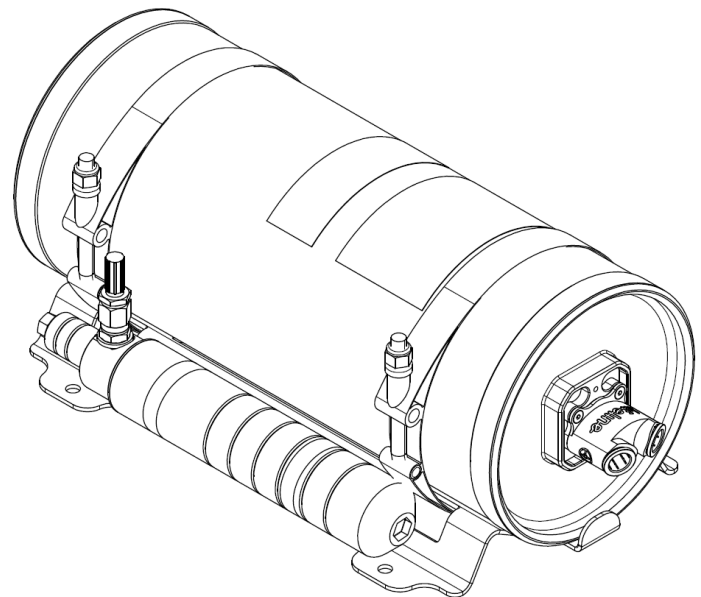

The position of the outlet on the cylinder may be adjusted using the three M3 bolts. When replacing the outlet, ensure that the O-ring is in place around the outlet on the cylinder. It is recommended to lightly grease the O-ring.

**Take care not to touch or damage the foil disc at the end of the cylinder, this may cause the extinguisher to leak and loose suppressant.**

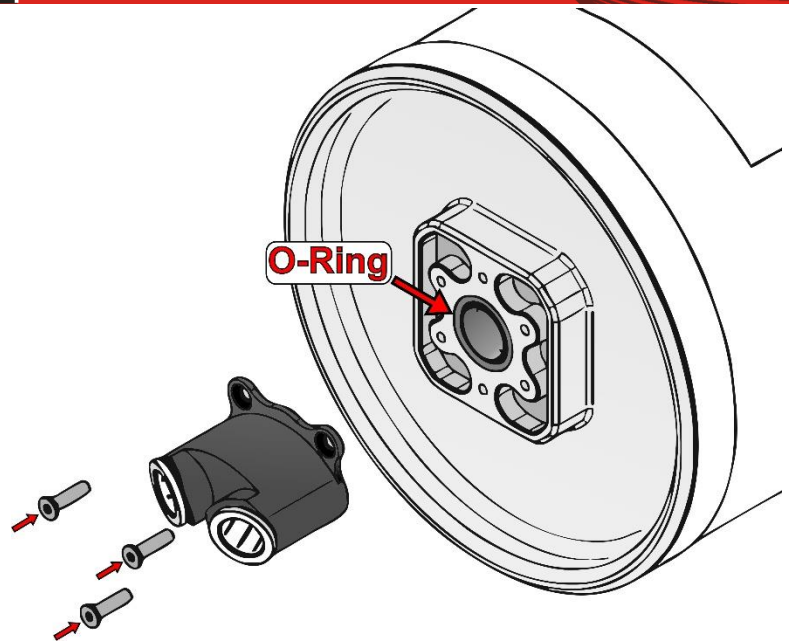

Figure 3 Changing the orientation of the Outlet

Ensure that the correct outlet is used for your cockpit volume.

The **BLACK** outlet is for cockpits with a free volume of 1.7m<sup>3</sup> to 3.14m<sup>3</sup>.

Free volume is the volume of empty space within the compartment that the cockpit nozzle can spray into (excluding seats, dashboard, electrical equipment boxes, door foam, roll cage, spares etc.).

Other colour outlets are for smaller cockpit volumes.

These volumes must match the volume indicated on the label on the cylinder.

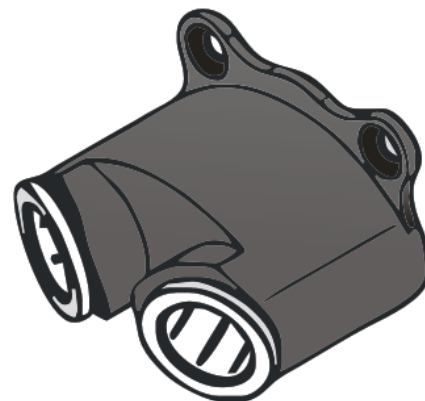

1.7 - 3.13m<sup>3</sup>

Figure 4 Use the correct outlet for your cockpit and system

## 2 Nozzle Mounting

Zero EV contains three nozzles, one black and red nozzle for use in the cockpit, and two blue nozzles for use in the engine bay.

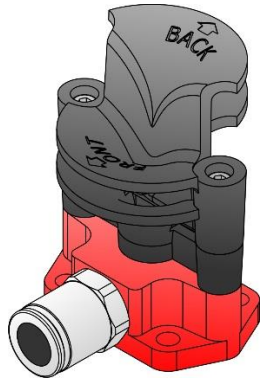

Figure 5 Cockpit Nozzle

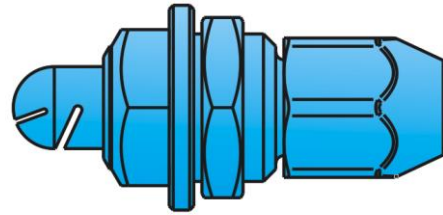

Figure 6 Engine Nozzle

### 2.1 Cockpit Nozzle

The cockpit nozzle should be mounted centrally in the vehicle, between the front seats of a saloon car. The nozzle discharges to the front and rear of the cockpit and is marked to indicate the correct orientation.

For prototypes or other rear engine cars, the nozzle can be brought forward to be inline with the front of the seat.

**Only fit the cockpit nozzle in the cockpit, do not place any other nozzles in the cockpit, even in fully Electric Vehicles without internal combustion engines.**

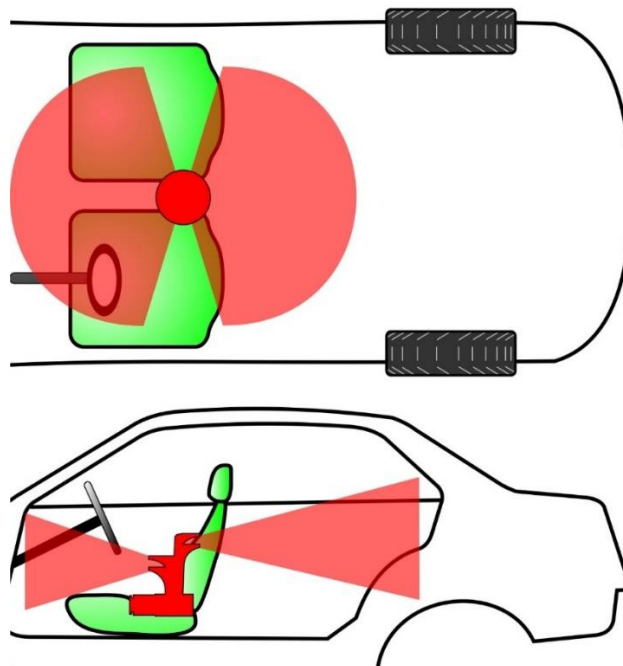
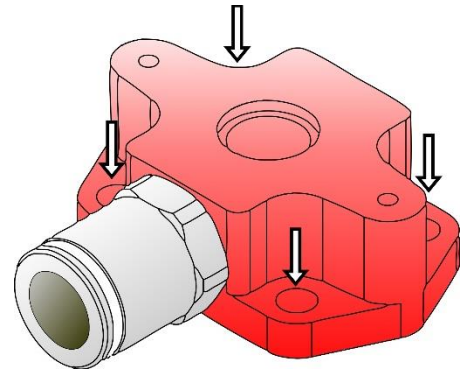

Figure 7 Cockpit Nozzle spray pattern and recommended location (for saloon/GT cars)

Excessive obstruction around the nozzle could reduce the effectiveness of the extinguisher.

To mount the nozzle, first fix the red base of the nozzle using four, M5 cap head bolts, orientating the connector towards either the front or rear of the vehicle, depending on the cylinder location.



**Figure 8 Cockpit Nozzle Base**

Fit the centre and top parts of the nozzle to the base using the supplied M3 bolts (2Nm Max). Ensure the nozzle is correctly orientated ie. "Front" marking pointed towards the front of the vehicle.

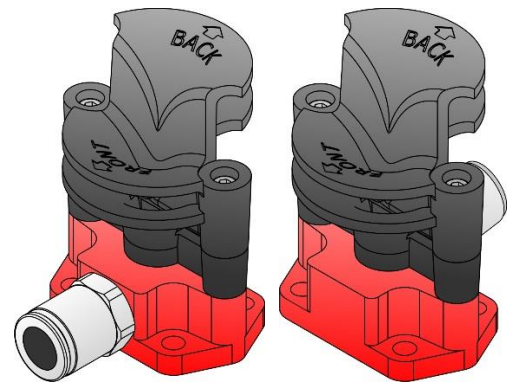

**Figure 9 Depending on cylinder location, the 10mm connector may point towards the front or rear of the vehicle**

## 2.2 Engine Nozzles

The two Engine Nozzles should be located on the bulkhead of the engine bay, equidistant apart, pointing towards the engine. The nozzles should be high up and horizontally mounted.

If the vehicle does not have an internal combustion engine, the Engine Nozzles should be directed at other likely sources of fire on the vehicle (motors, inverters, batteries etc.). In all cases, **the engine nozzles must not be located within the cockpit.** Contact Lifeline if further guidance is required.

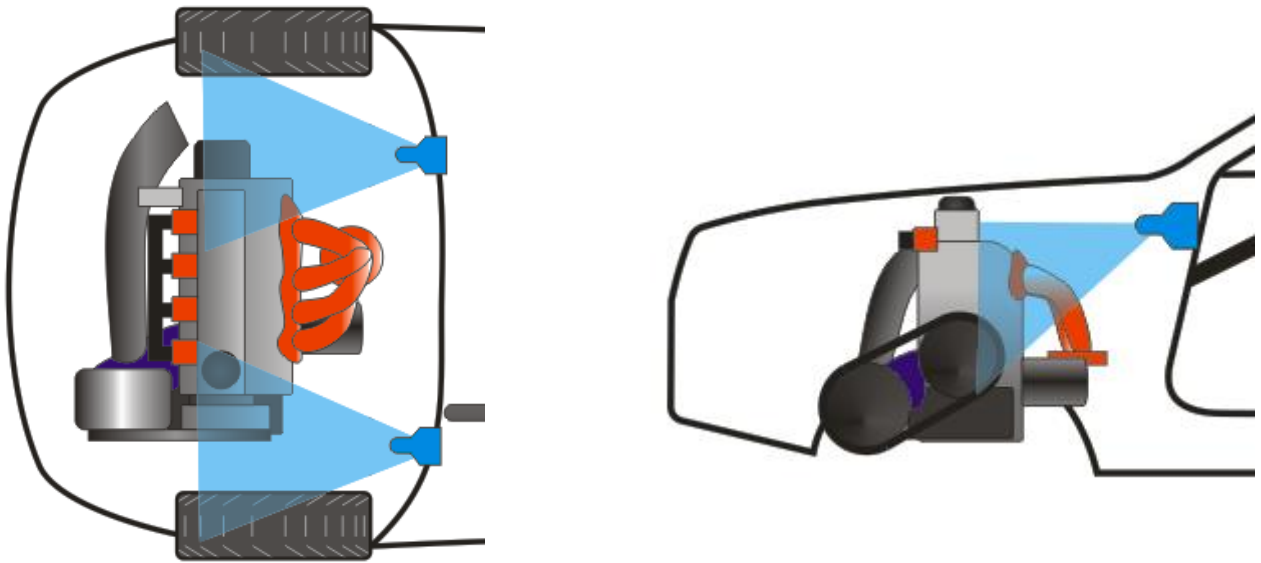

Figure 10 Engine nozzle positions for a transverse engine

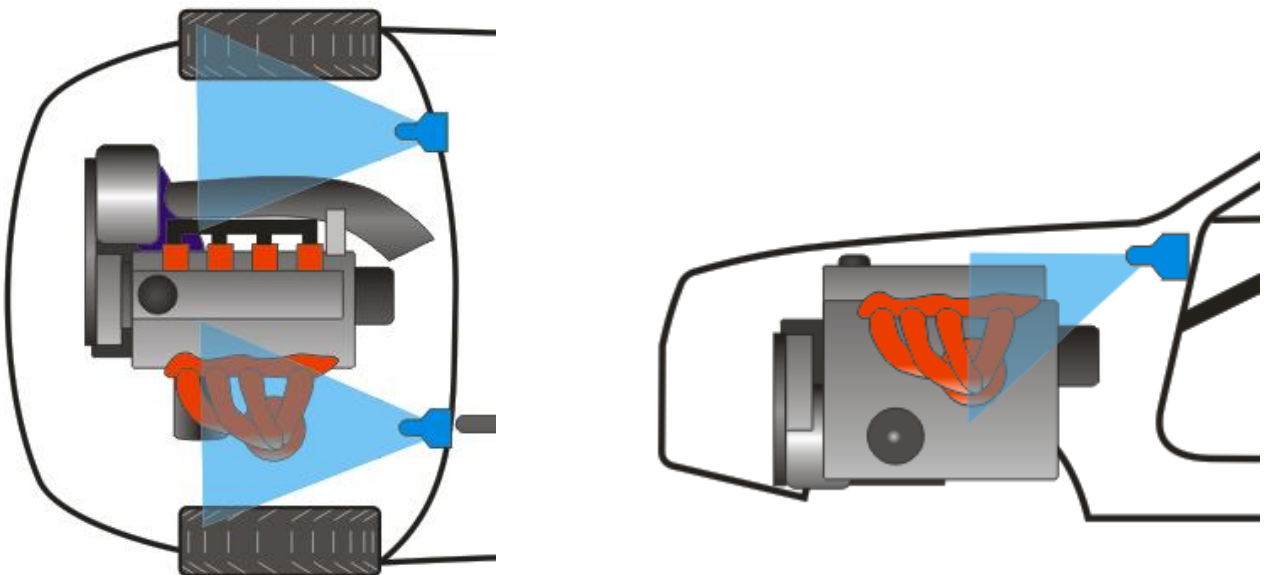
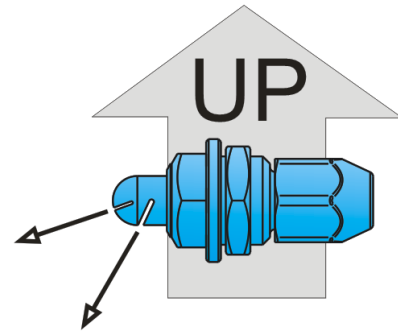

Figure 11 Engine Nozzle positions for a longitudinal engine

The nozzles must be mounted horizontally, with the face marked TOP pointing upwards.



**Figure 12 Correct orientation of Engine Nozzles**

The nozzles should be either mounted to brackets or engine bay bulkhead. A Ø20 panel cut-out is required.

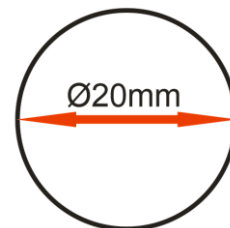

**Figure 13 Engine Nozzle panel cut out**

To secure, hold the nozzle in the correct orientation with a 19mm spanner and tighten the 22mm lock nut.

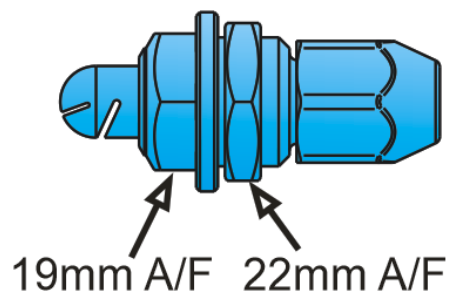

**Figure 14 Spanner sizes for nozzle and lock nut**

## 3 Delivery Network

### 3.1 Tubing

Connect the cylinder to the nozzles using the 10mm and 8mm tubing supplied, following the schematic diagram below. The correct sized tubing must be used as per this diagram, otherwise the system will not function correctly, and the homologation will be voided. The pipe lengths to each of the engine bay nozzles should be kept as equal as possible for best suppressant discharge.

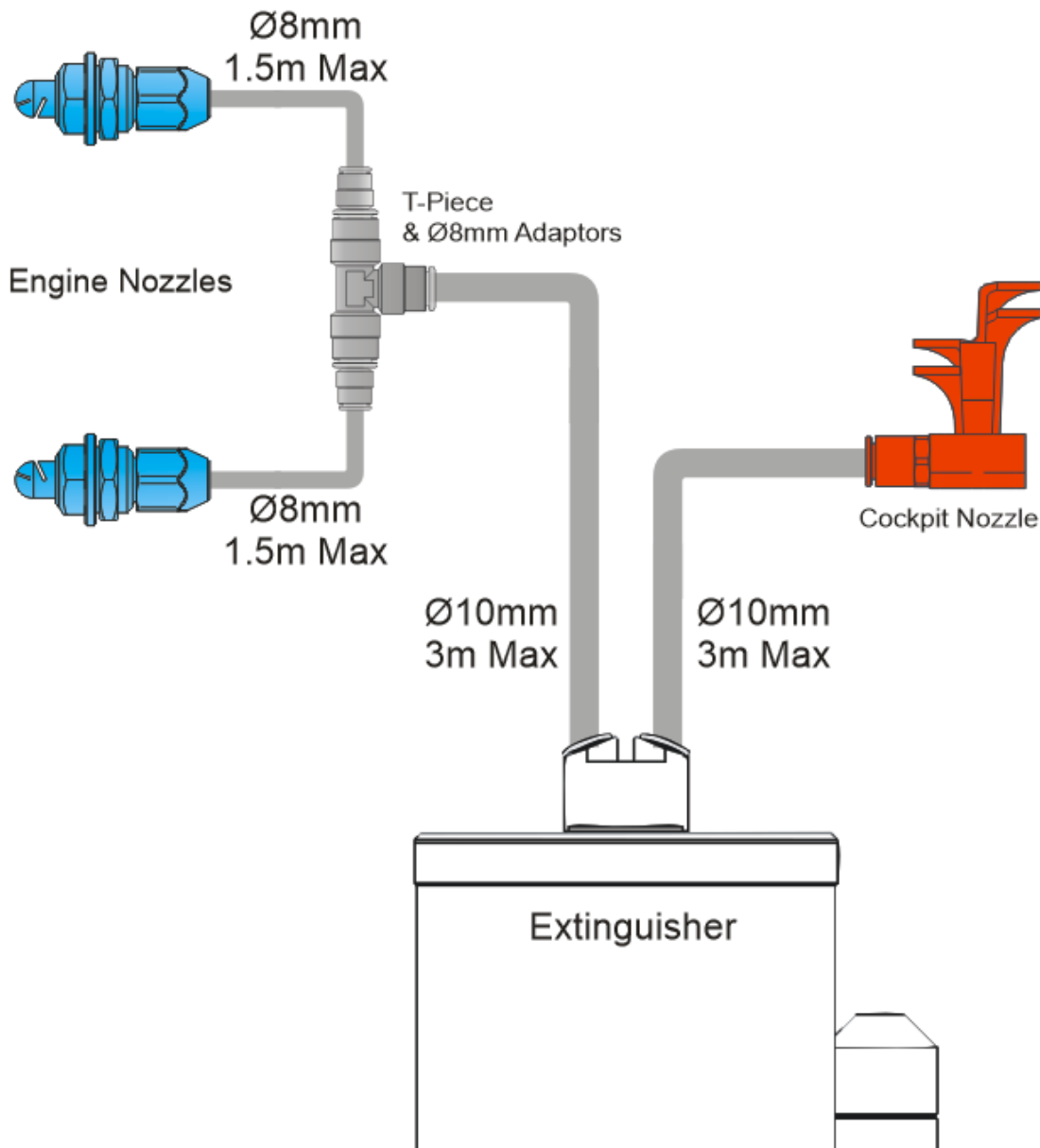

Figure 15 System Delivery Network

Bulkhead fittings may be used on all Ø10mm tubes. 90° fittings may be used on the extinguisher outlets and on the cockpit tubing. These can be purchased separately.

Lifeline operates a policy of continual improvement and reserves the right to change details or advice given in this Technical Bulletin without notice. For latest advice contact Lifeline Technical Department on +44 (0)24 7671 2999 or sales@lifeline-fire.co.uk



When cutting the 8mm and 10mm tube, use a dedicated tube cutter, ensuring that there are no sharp edges and that the tube remains circular. Do not use a hack saw or similar tool; this will leave a jagged edge which will damage seals in the connectors

Form the tube using a pipe bender taking care not to create a kink which could restrict flow. Minimum bend radius of the tube is shown below. Use as few bends as possible for smooth flow of suppressant and best performance.

Tube Ø	Minimum Bend Radius
8mm	30mm when using pipe bending tool
10mm	30mm when using pipe bending tool

Secure the tube using cable ties and saddles or P'clips. Tubes passing through a bulkhead must be protected with a rubber grommet.

### 3.2 Tube Connectors

The cylinder, cockpit nozzle, T-Piece and adaptors use push fit connectors. To fit, push the tubes firmly into the connectors ensuring they are fully inserted past the internal o-ring seal. Applying light assembly lubricant to the end of each tube can aid fitting.

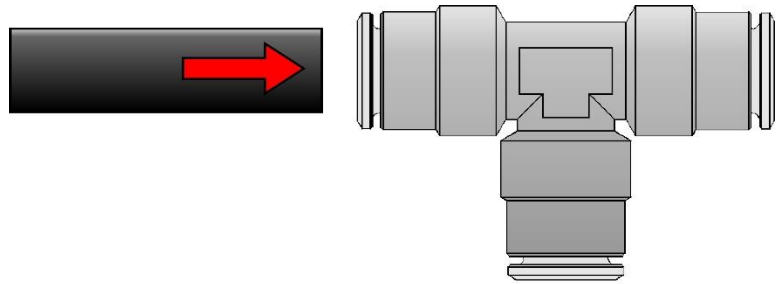

Figure 16 Connecting tube push fit connectors

To disconnect the tubing, compress the silver collet around the tube and pull the tube out.

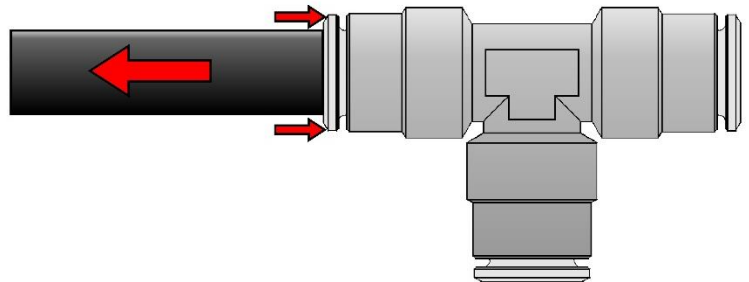

Figure 17 Disconnecting tube push fit connectors

The engine nozzles use compression fittings.

Push the 8mm tubing through the compression nut and brass olive. Hold the nozzle with a 19mm spanner or socket while tightening the compression fitting with a 17mm spanner.

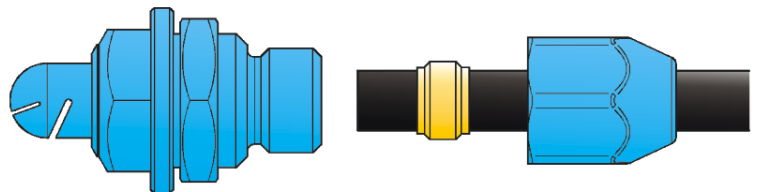

Figure 18 Engine Nozzle compression fitting

## 4 Electrical Activation

The electrical system for Zero EV MUST be independent of other vehicle systems. This is so the extinguisher can still fire in the event of an electrical failure. The system may be integrated into a vehicle wiring loom if it remains an independent circuit.

**Do not connect the extinguisher circuit to a common ground or power source.** Integrating the electrical system into other electrical circuits will cause the extinguisher to malfunction and it will likely fire.

**Do not disassemble or modify the Control Box.** This assembly is homologated by the FIA and must be used as supplied. Modifying the control box may cause the system to malfunction.

### 4.1 Control Box & Activation Switches

The Control Box must be located where it can be reached by the driver/co-driver. E.g. centre of dashboard or centre console area.

Ensure that the LED indicator lights are visible to the driver. Use M4 countersunk bolts to secure the Control Box.

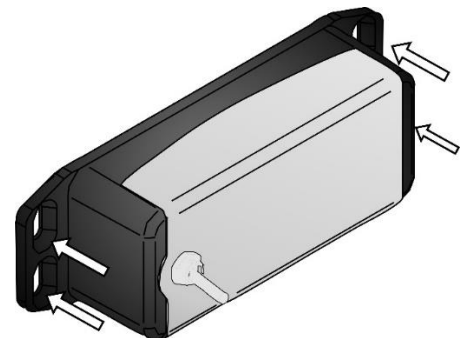

Figure 19 Control Box mounting slots

One activation switch must be located inside the cockpit, within reach of the driver & co-driver, when seated with harnesses on. It is recommended to mark this switch with the small circular “E” sticker that is supplied, or other label marked “FIRE”, “EXTINGUISHER” etc.

The second switch must be located externally directly next to the electrical cut-off switch in accordance with FIA regulations. The circular “E” sticker must be placed next to the external switch.

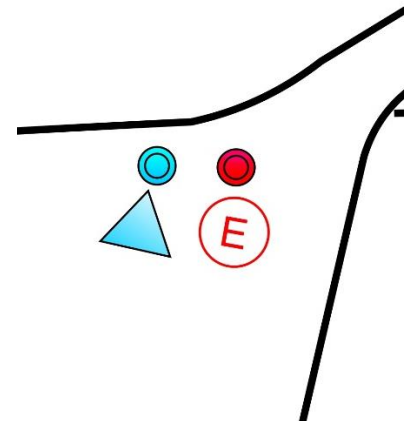

Figure 20 Locate the external switch next to the electrical cut off

Use a  $\varnothing 13.6$  panel cut out and the supplied lock nut to secure the switches.



Figure 21 Activation Switch panel cut out



#### 4.2 Wiring

Wire the system as per the wiring diagram on page 12. Connectors with flying cables are supplied, cut or extend these cables as required. Solder the joints and seal with glue lined heat shrink to protect from water ingress. There are four coloured wires in the circuit:

**Blue & Brown:** Connect to the switches, wiring the switches in parallel. Do **NOT** wire the switches in series, the system will not fire!

**Black & White:** Connect to the extinguisher.

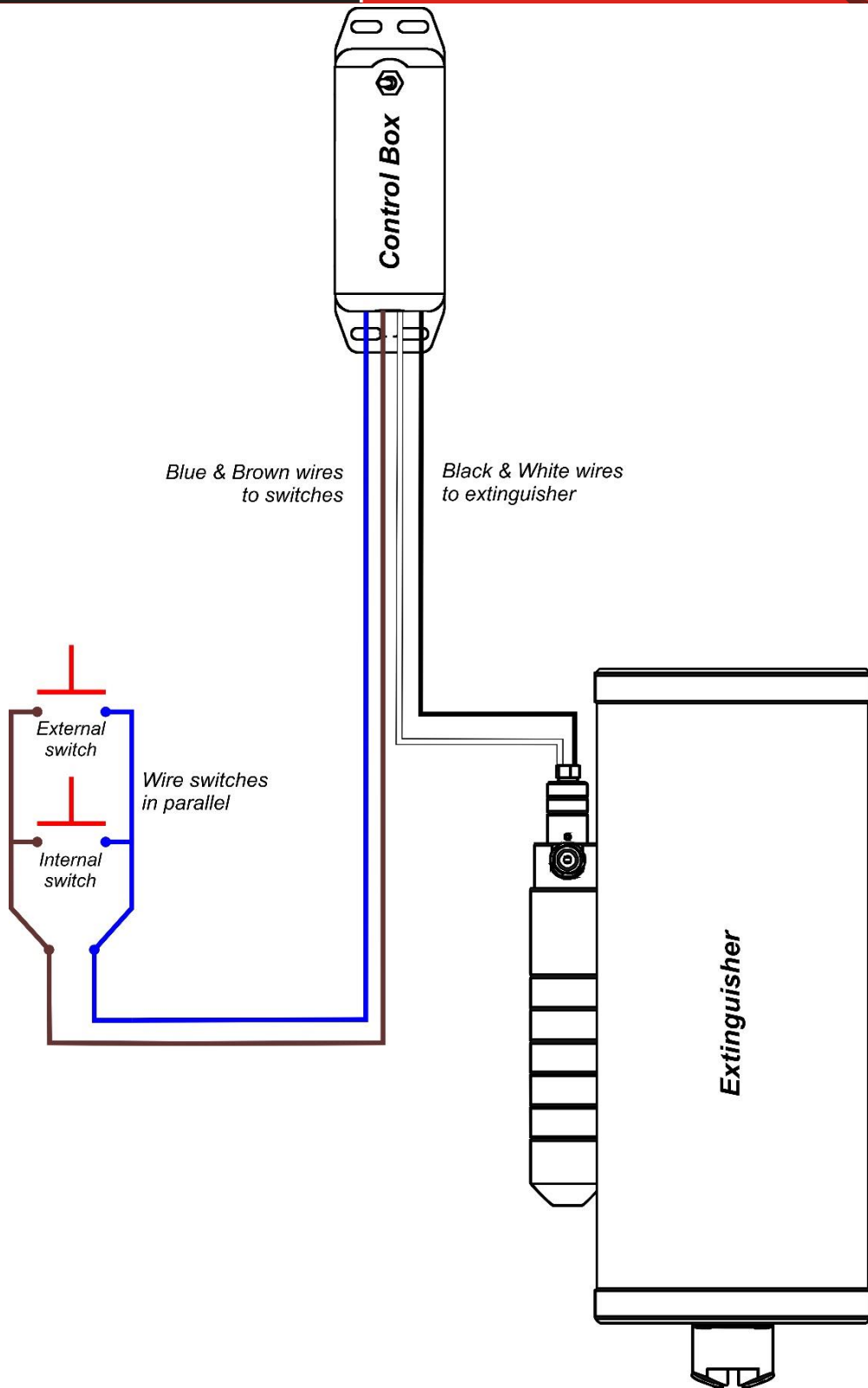

**Figure 22 Zero EV Wiring Diagram**

## 5 System Checking and Maintenance

### 5.1 Electrical Test

The Control Box has two modes, Test and Armed. When the vehicle is not on circuit or on stage, set the Control Box to Test mode to prevent accidental activation. It is strongly recommended to test the system as described below before every session. This test will also be performed during scrutineering checks.

To test the integrity of the electrical system:

1. Set the Control Box to Test mode by using the switch.
2. Press one of the activation switches. The Control Box will then perform its test cycle.
3. If the system is correctly wired and the battery condition is good, the Amber LED will illuminate for 5 seconds and then go out.
4. If the Amber LED flashes, there is an error in the system:
  - a. 2 flashes = Low/Faulty Battery. The Battery must be replaced.
  - b. 3 flashes = Circuit Fault. Check that the wiring circuit is correct and that there are no breaks in the circuit.

If the system is showing no faults, it can be set to Armed mode using the switch on the Control Box. The Red LED will now flash every 3 seconds. If the LED does not flash, there is a fault in the system and the system will not fire!

### 5.2 Control Box Battery

Lifeline recommend removing the Control Box battery between events to extend battery life.

To change the battery, remove the 4 Pozi screws on the rear of the Control Box. The battery is attached to the lid by a cable tie, cut this cable tie to release the battery from the lid. Replace the battery, using a small cable tie to secure it to the lid and reconnect to the battery terminal.

**Only use alkaline PP3 batteries to spec 6LR61.**

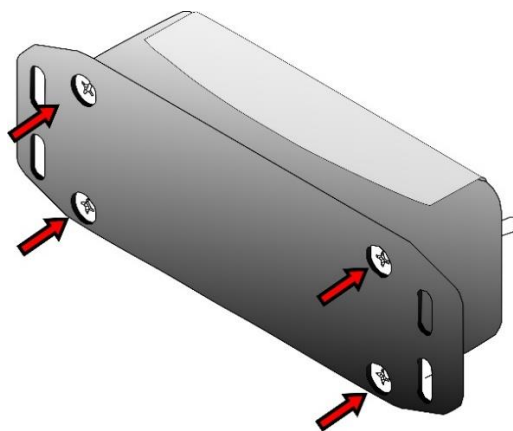

**Figure 23 Remove the 4 screws at the rear of the Control Box to change battery**



### 5.3 Cylinder Maintenance

Check that the cylinder has a valid maintenance label. The cylinder must be serviced every two years by Lifeline or an approved Lifeline service agent. Do not attempt to service the system yourself or have the system serviced by a non-Lifeline approved service agent, this will void the system's validity and potentially cause injury.

Regularly check the weight of the extinguisher against that shown on the label. Some variances will be found when using difference weight equipment. If the system measures significantly underweight, return the system to Lifeline for repair

<b>System Part Number</b>	
<b>System Serial Number</b>	
<b>Date of Manufacture</b>	
<b>Service 1 Date</b>	
<b>Service 2 Date</b>	
<b>Service 3 Date</b>	
<b>Service 4 Date</b>	
<b>Service 5 Date</b>	

## 1. INSTALLATION DU SYSTEME D'EXTINCTION / FIRE EXTINGUISHER SYSTEM INSTALLATION

### 101. INSTALLATION DANS L'HABITACLE / COCKPIT INSTALLATION

- a) Emplacement et orientation du corps

*Location and orientation of body*

Transversally or longitudinally, and within the safety cell/roll cage

- b) Emplacement et orientation des buses

*Location and orientation of nozzles*

Aimed as shown in E1-2 below

- c) Précaution à prendre lors de l'installation du système

*Special care to take with the installation of the system*

**Ensure nozzle is not excessively obstructed. Ensure cylinder is not positioned where it could be damaged or exposed to extreme heat**  
See Lifeline Technical Bulletin 059 for detailed installation instructions

E1-1) Installation dans l'habitacle (emplacement et orientation du corps)

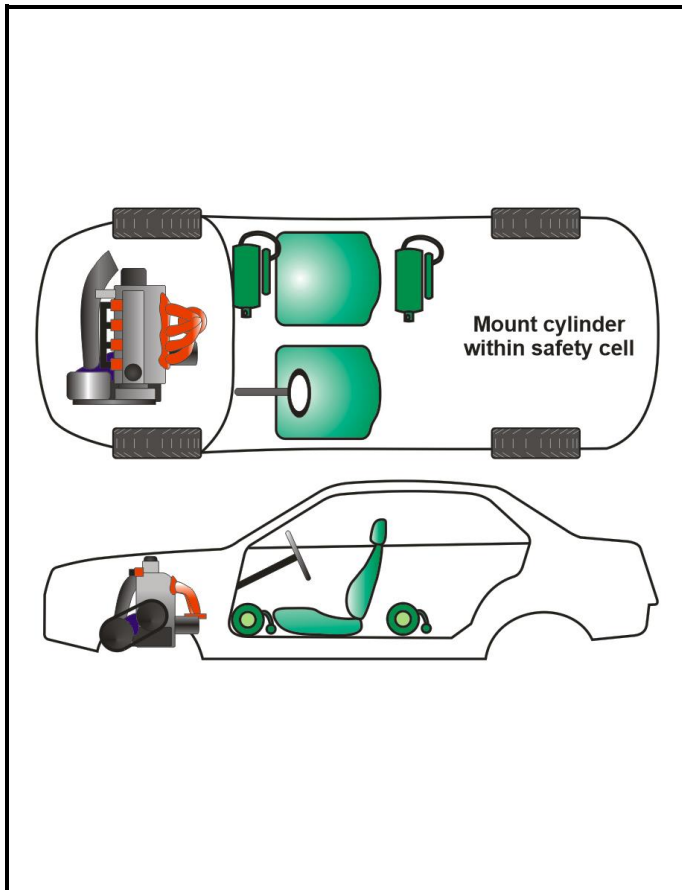

E1-2) Installation dans l'habitacle (emplacement et orientation des buses)

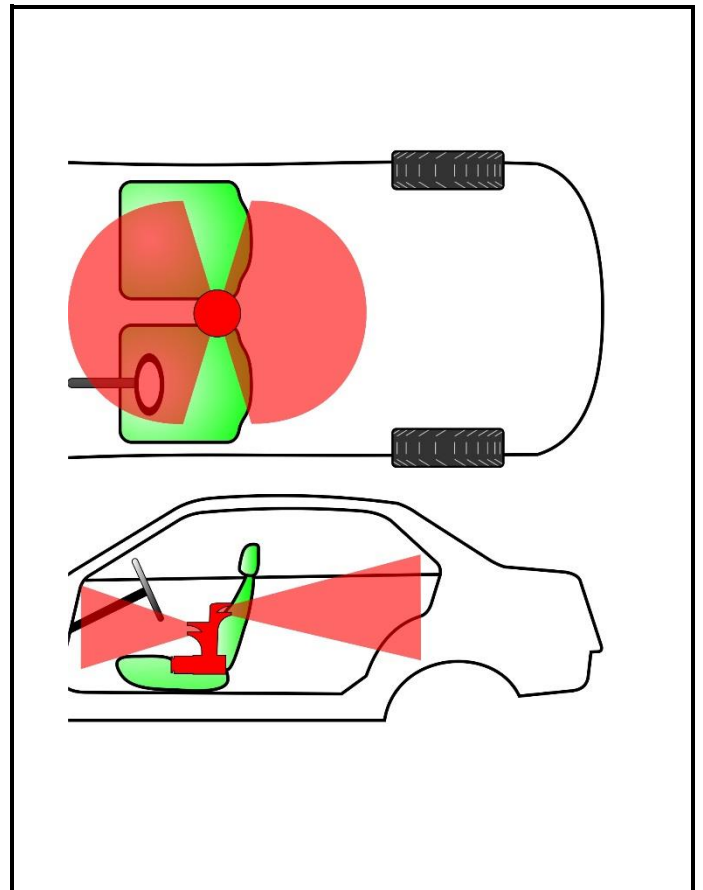

102. INSTALLATION DANS LE MOTEUR / ENGINE INSTALLATION

a) Emplacement et orientation du corps

*Location and orientation of body*

**Transversally or longitudinally, and within the safety cell/roll cage**

b) Emplacement et orientation des buses

*Location and orientation of nozzles*

**2 nozzles on either side of the engine, 3<sup>rd</sup> nozzle targeted at likely sources of ignition**

c) Précaution à prendre lors de l'installation du système

*Special care to take with the installation of the system*

**Nozzles must not be obstructed in any way. See Lifeline Technical Bulletin 059 for detailed installation instructions**

E2-1) Installation dans le moteur (emplacement et orientation du corps)

*Engine installation (location and orientation of body)*

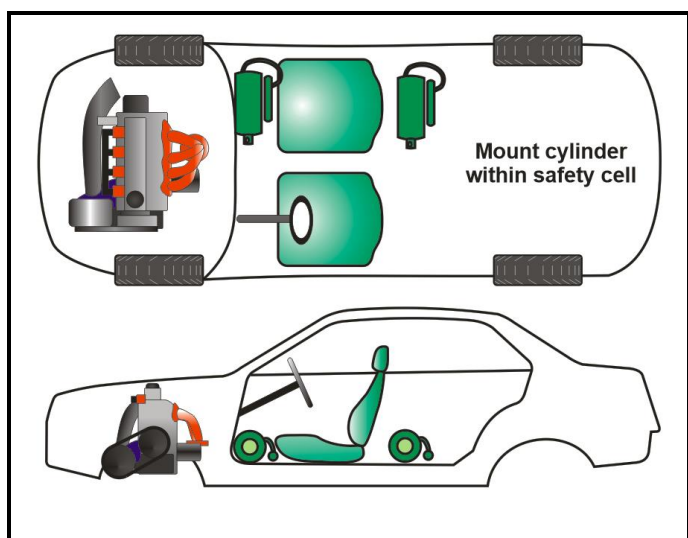

E2-2) Installation dans le moteur (emplacement et orientation des buses)

*Engine installation (location and orientation of nozzles)*

